



# AMOS

MFG., INC.

[WWW.AMOS-MFG.COM](http://WWW.AMOS-MFG.COM)





*Reduction and Recycling Solutions*

INDUSTRIAL  
SHREDDERS

SYSTEM  
SOLUTIONS

Amos Mfg., Inc. is a US manufacturer of industrial size reduction shredders and separation equipment with over 40 years of experience.

# AMOS AND THE IFMC

PRIVATELY-  
OWNED

BASED IN THE  
UNITED STATES

45+ YEARS OF  
EXPERIENCE

1,500 TEAM  
MEMBERS

DEDICATED IN- HOUSE  
OPERATIONS TEAM

FULLSCALE PARTS &  
SERVICE DEPARTMENT

DEDICATED WELD,  
PAINT, AND ASSEMBLY  
FACILITIES

MULTIPLE LASERS,  
PRESS BRAKES, AND  
TEMPLATE BURNERS

1.8 MILLION SQUARE FEET OF  
MANUFACTURING SPACE

THREE POWDER  
COAT FACILITIES

IFMC | INTERDEPENDENT FREE MARKET CONSORTIUM



# AMOS Mfg. Working Together with Customers

Customer  
Journey



Sales



Engineering

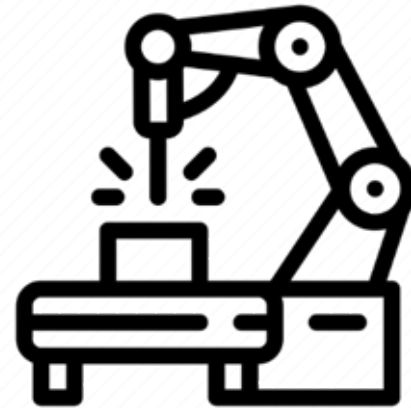

Manufacturing

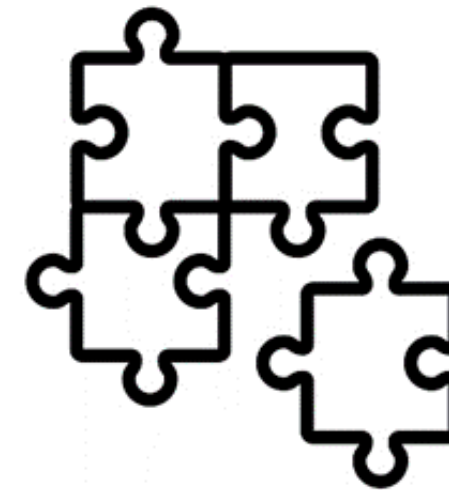

Integration



Installation

# BATTERY RECYCLING PROCESS

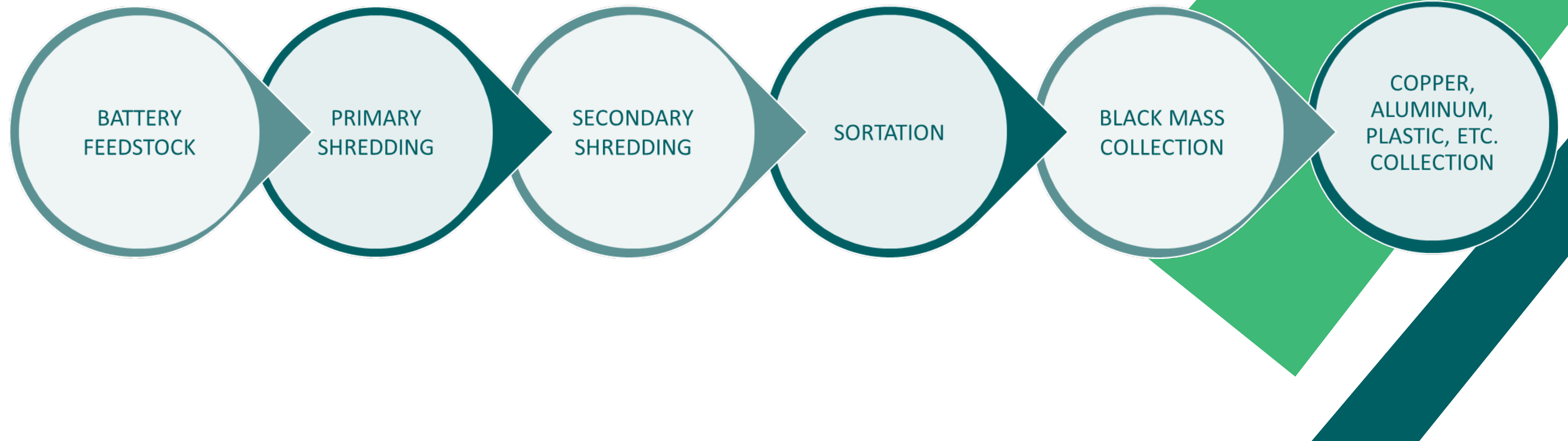

# BATTERY SHREDDING

## KEY FEATURES

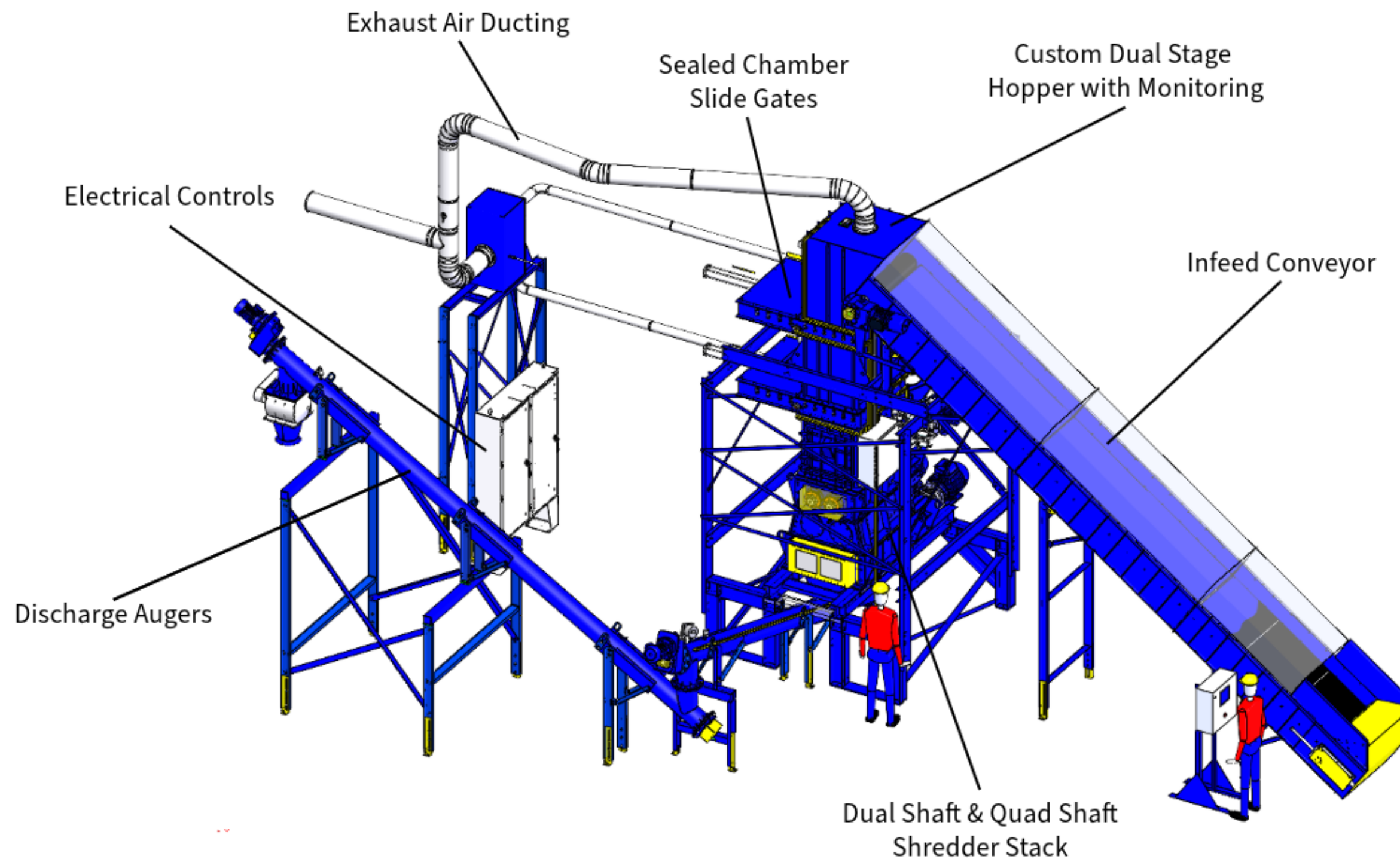

- ▶ INFEEED CONVEYOR
- ▶ HEAVY DUTY STRUCTURAL SUPPORTS
- ▶ CUSTOM CHAMBER WITH SLIDE GATES
- ▶ SAFETY FEATURES & MONITORING
- ▶ DUAL SHAFT SHREDDER
- ▶ QUAD SHAFT SHREDDER
- ▶ EXHAUST AIR DUCTING
- ▶ DISCHARGE AUGER



# CLOSED LOOP BATTERY RECYCLING SOLUTION

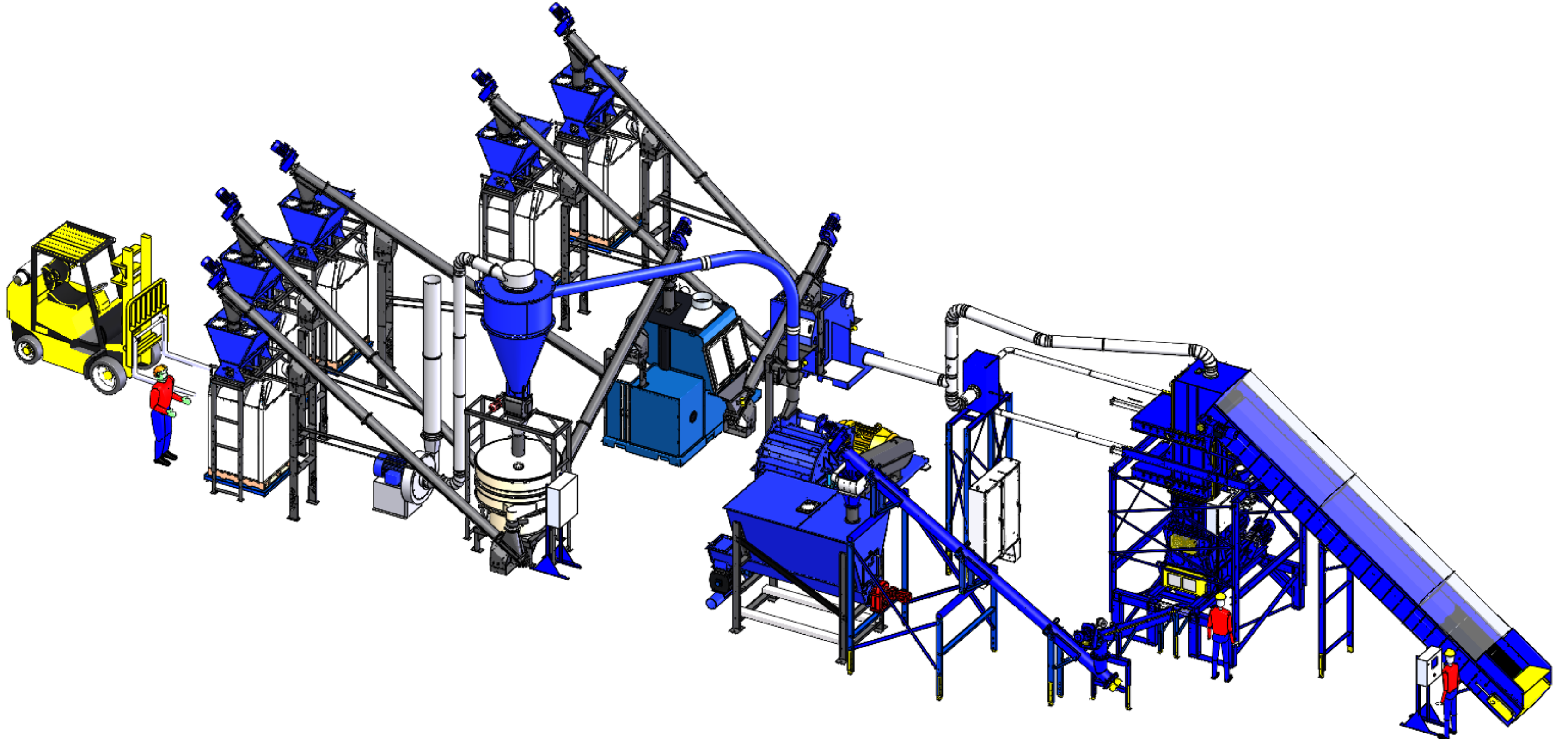

# SEPARATION SYSTEMS

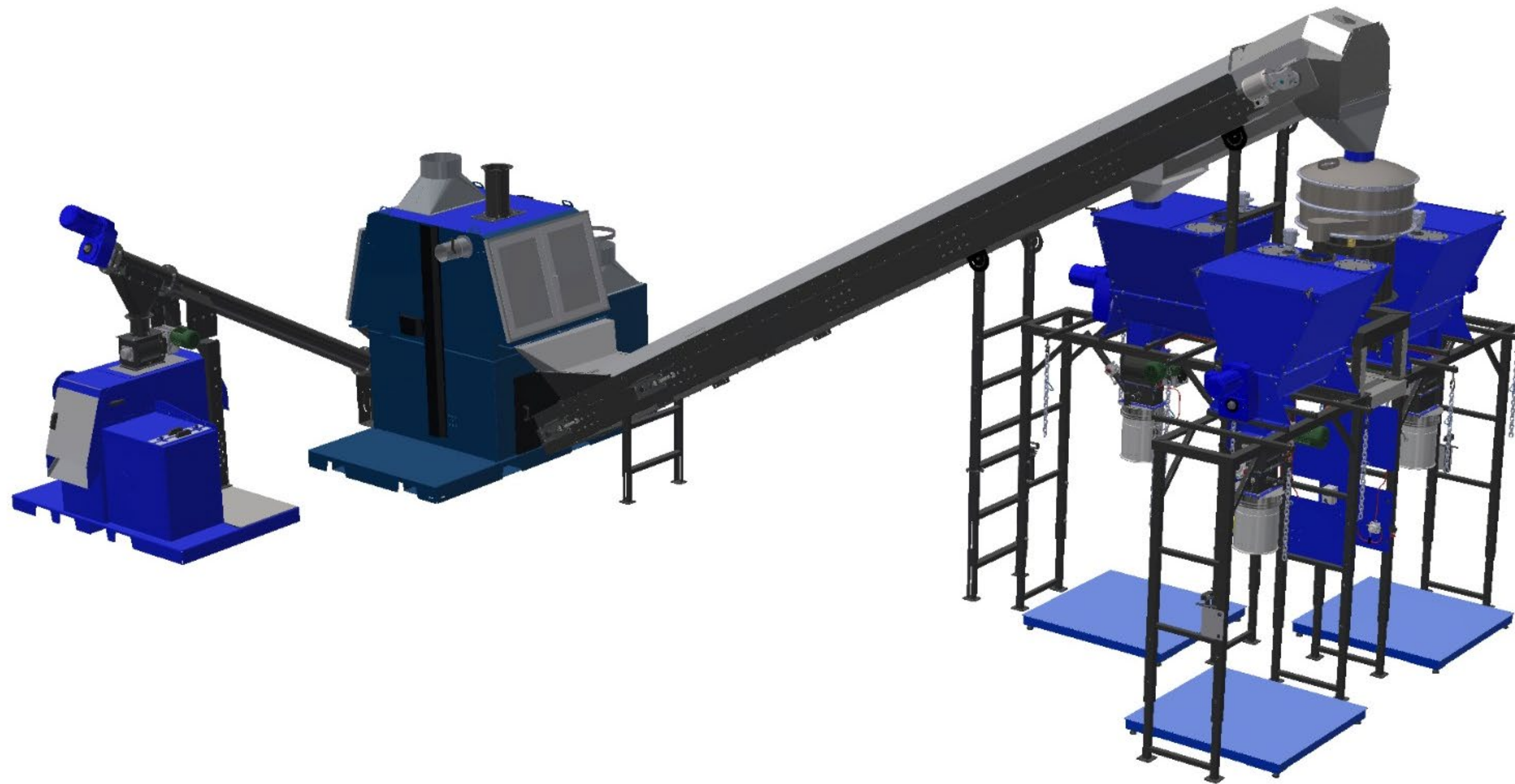



# DUALSHAFT SHREDDERS

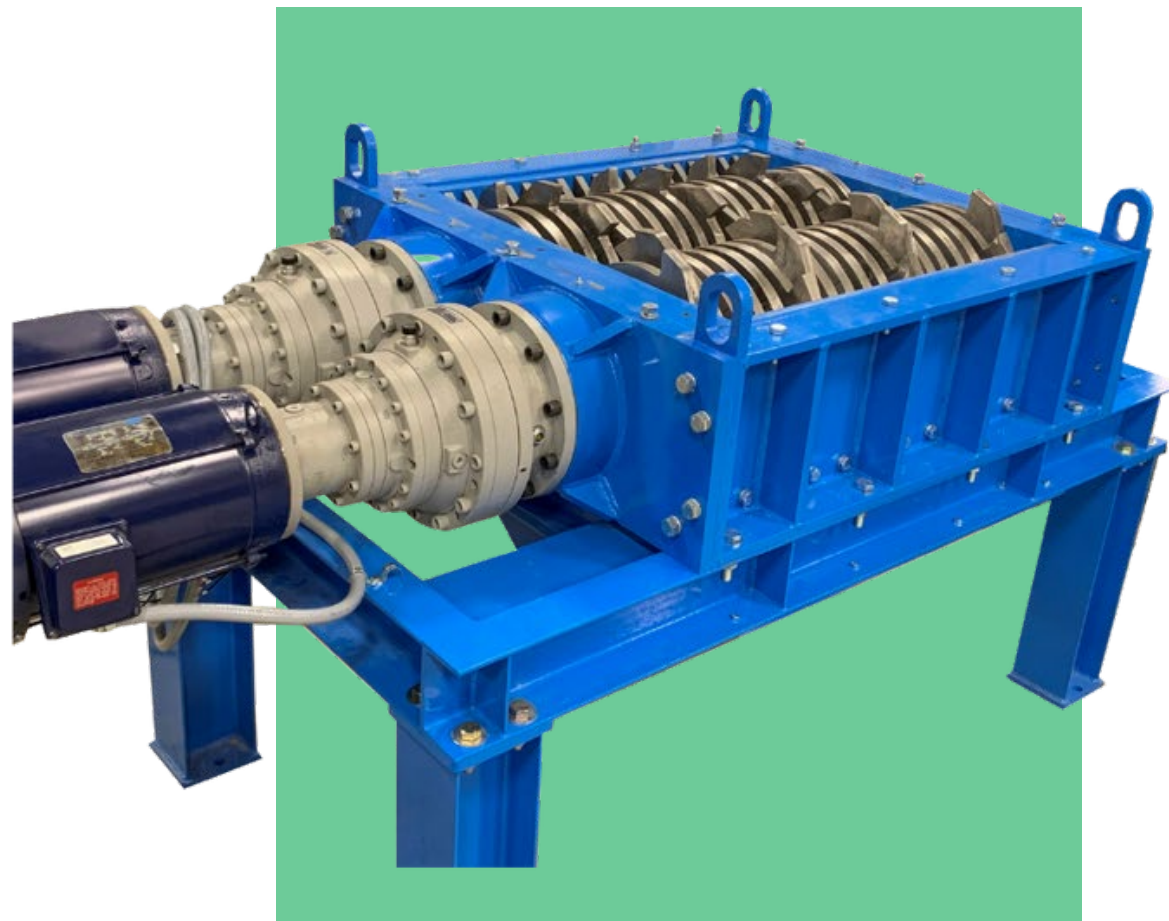

Offer a variety of cutter configurations to process material, while avoiding jams, to offer continuous throughput.

# QUAD SHAFT SHREDDERS

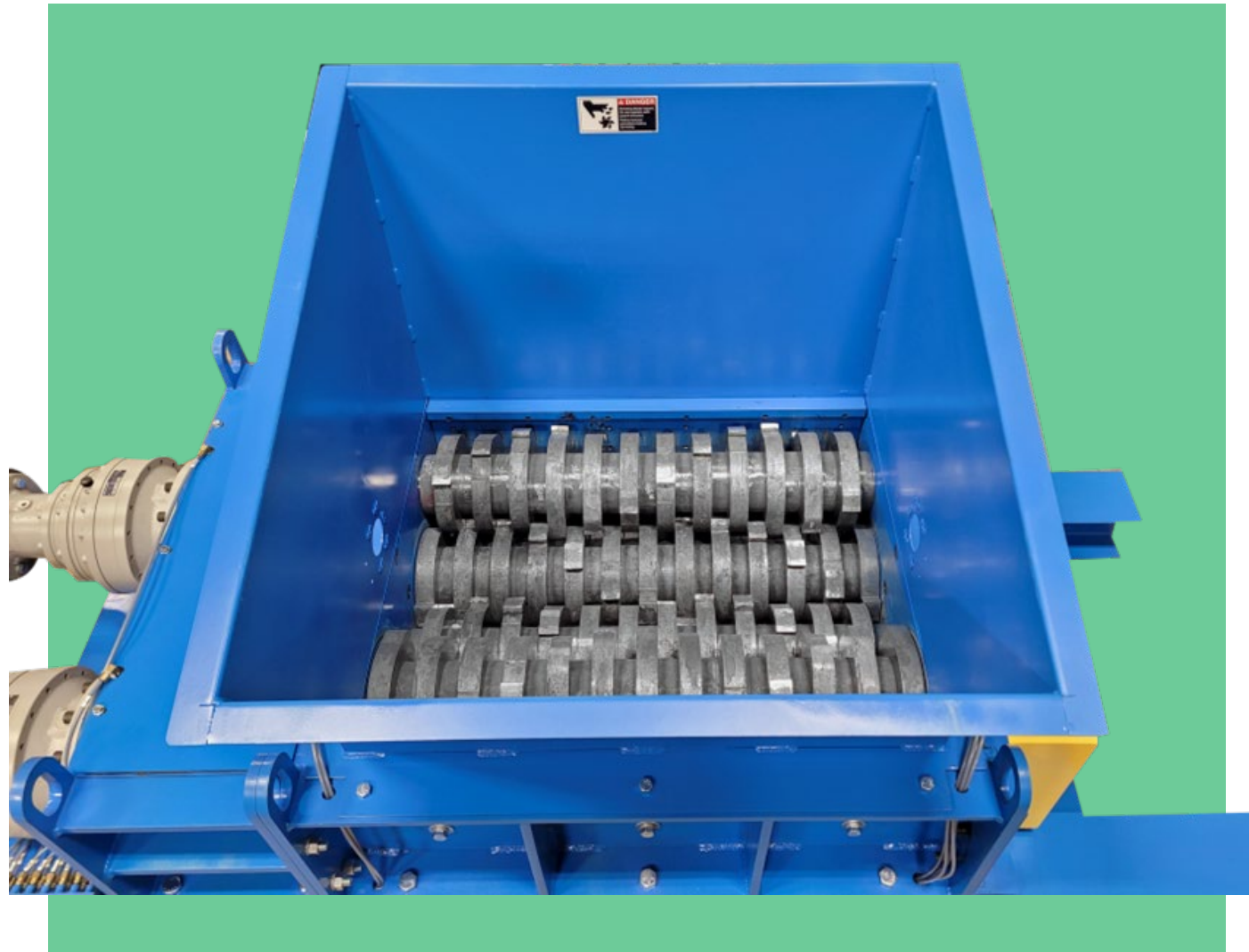

Utilize a sizing screen that circulates material until it reaches the desired particle size.



# CUSTOM DESIGNED SYSTEMS

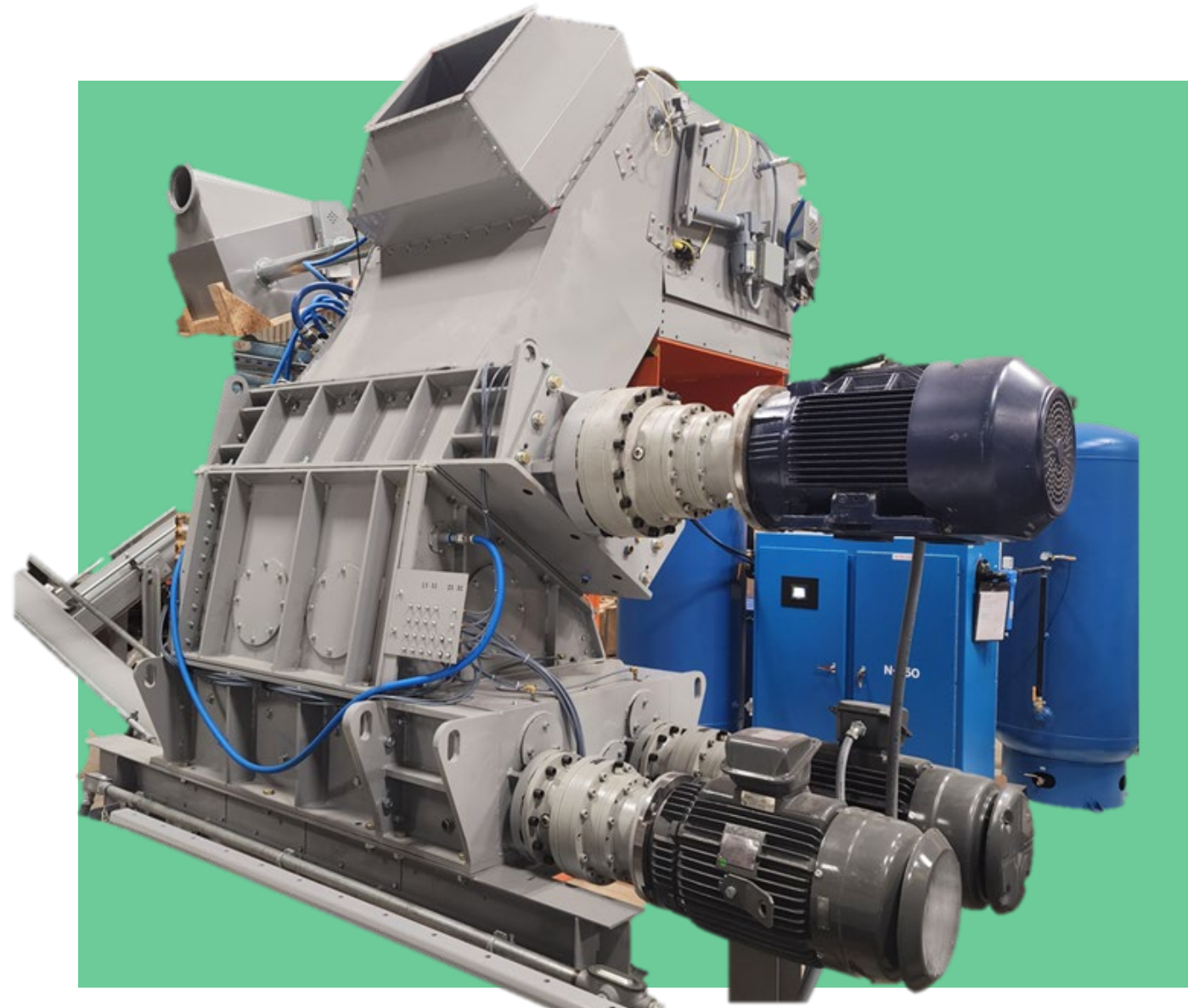

Application specific and engineered based on battery type and throughput volume.

# CONVEYORS & SEPARATORS



Screw Conveyors



Infeed & Discharge  
Conveyors

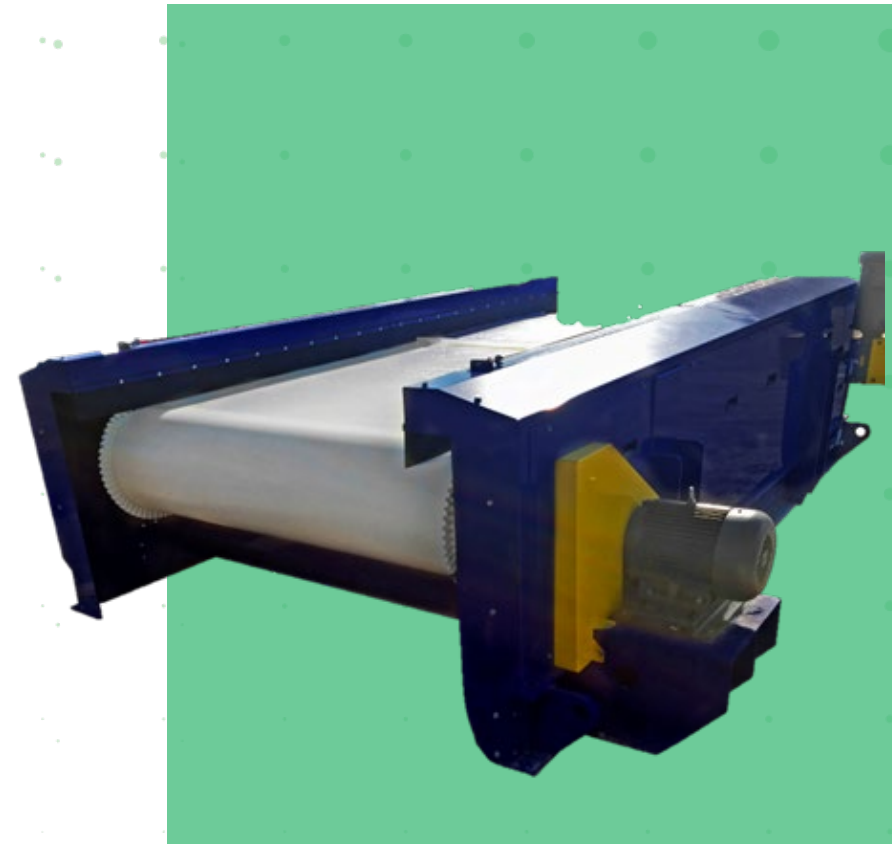

Magnetic Separators

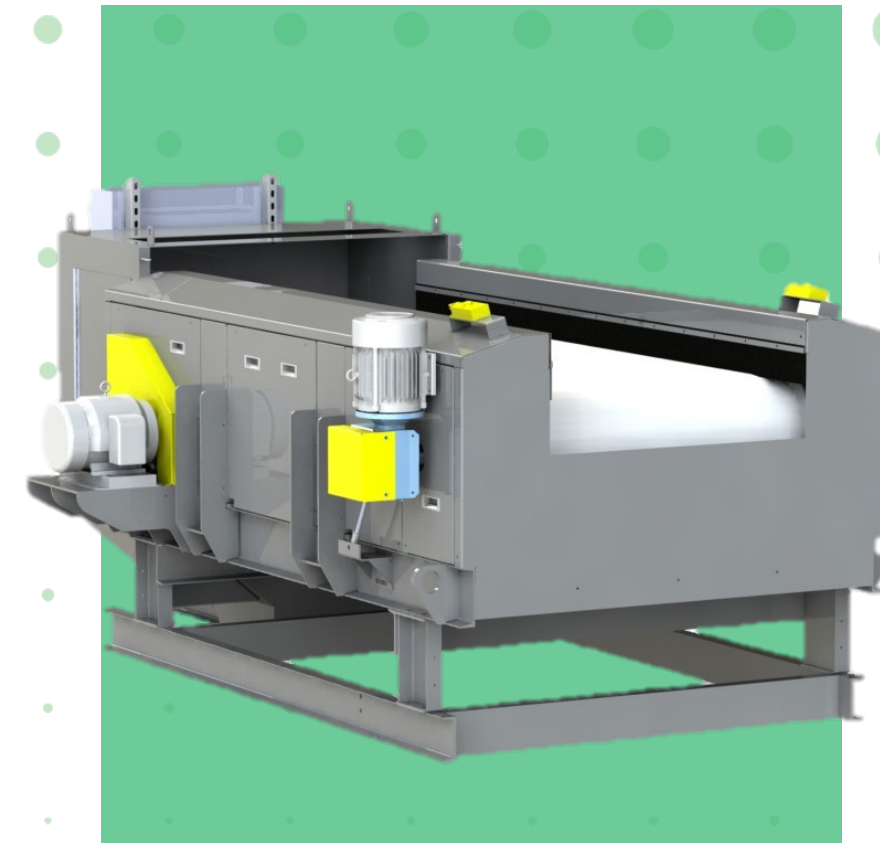

Eddy Current  
Separators



# ANCILLARY EQUIPMENT

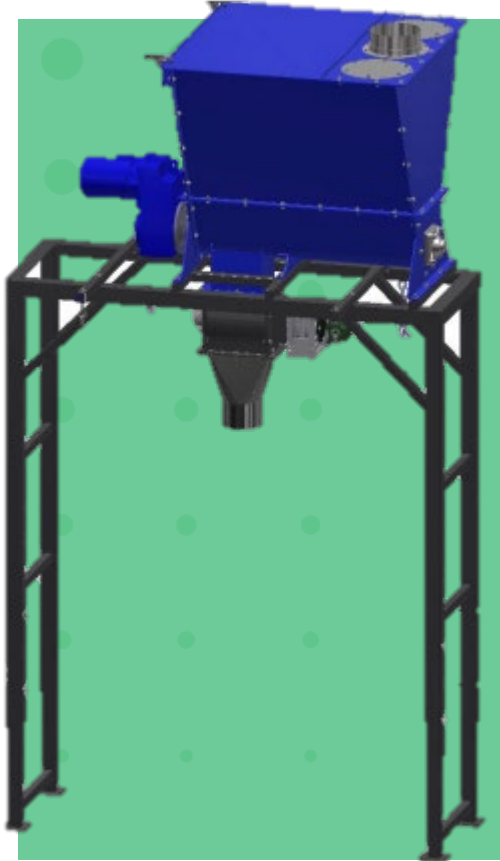

Bagging Stations

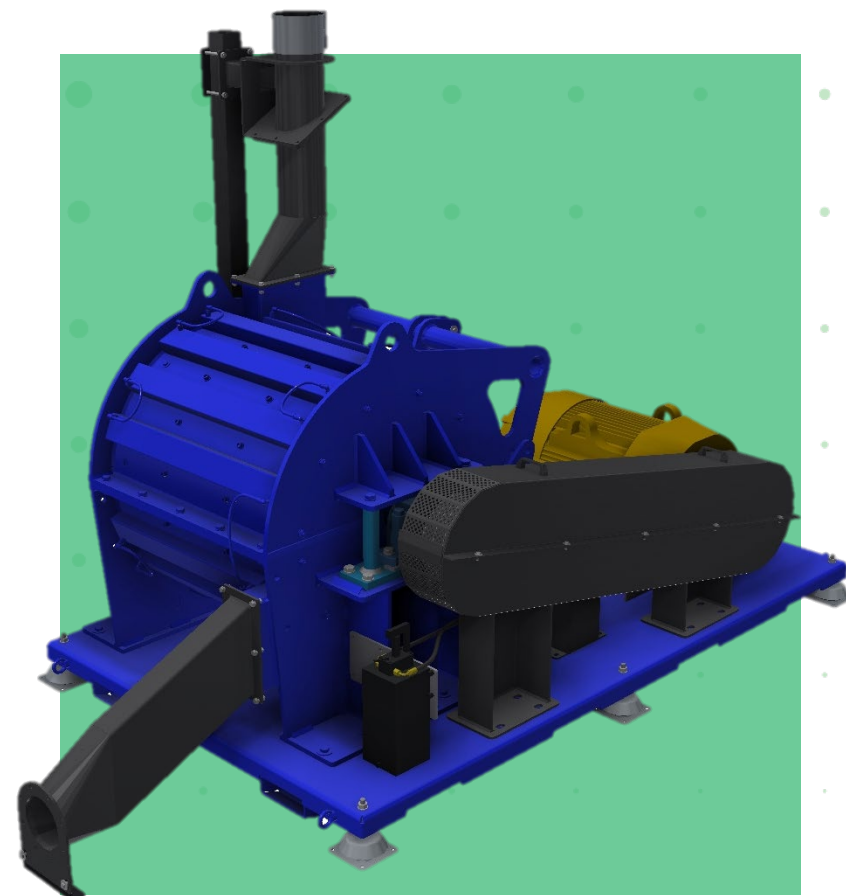

High-Speed Mills

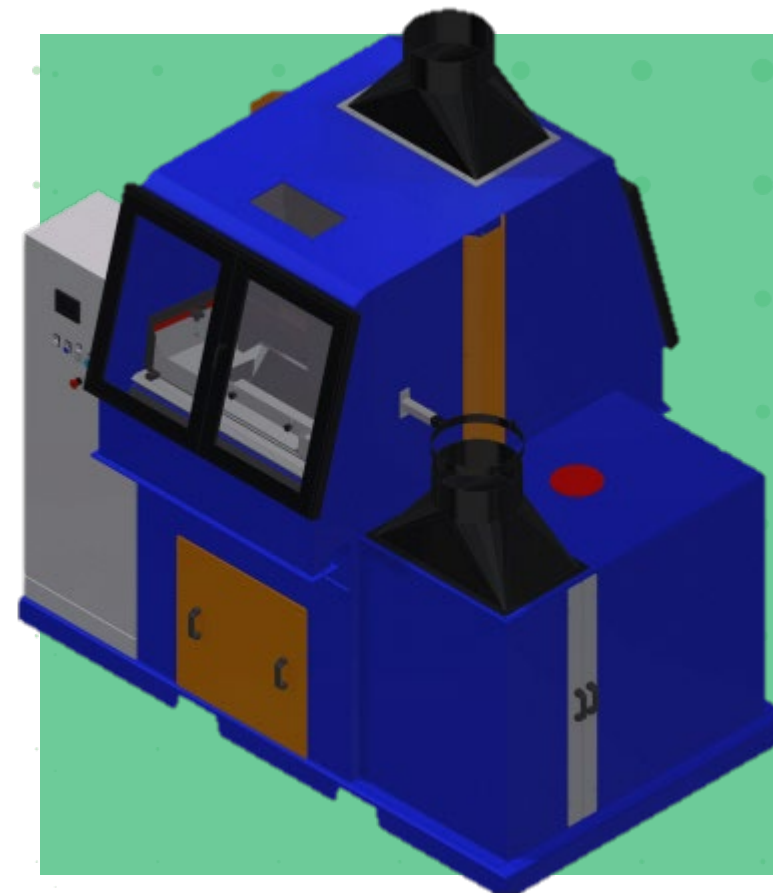

Air Separation Table



Gyratory  
Screeners

# Stay In Touch



Jordan Gruschke | Sales Manager

989-340-6731 | [jordan.gruschke@amos-mfg.com](mailto:jordan.gruschke@amos-mfg.com)

Dan Westergard | Lead Engineer

989-340-6513 | [dan.westergard@amos-mfg.com](mailto:dan.westergard@amos-mfg.com)



*Reduction and Recycling Solutions*

