

The logo for Anguil Environmental Systems, featuring the word "ANGUIL" in a bold, black, sans-serif font. Above the text is a horizontal red bar with a small "TM" trademark symbol at its right end.

ANGUIL™

# Air and Water Pollution Control Solutions for the Battery Market

Sandy Beal | Anguil Environmental Systems



# Anguil Fast Facts



## Products/Services:

- Air Solutions
- Water Solutions
- Energy Recovery Solutions



## Pollution Control:

- VOCs, HAPs, Odors, NOx
- Wastewater Treatment & Reuse



**1978**

FOUNDED BY GENE  
ANGUIL



**Milwaukee, WI**

CORPORATE  
HEADQUARTERS



**\$90 Mil+**

ANNUAL GLOBAL  
REVENUE



**200+**

PRIVATE EMPLOYEES



**5**

GLOBAL LOCATIONS



**2,400+**

INSTALLATIONS  
WORLDWIDE

**Anguil –  
Spooner Industries**

---

Europe

**Anguil  
Environmental  
Systems**

---

North & South America

**Anguil Asia**

---

China & Taiwan

**Anguil  
Environmental  
Systems  
Private Limited**

---

India

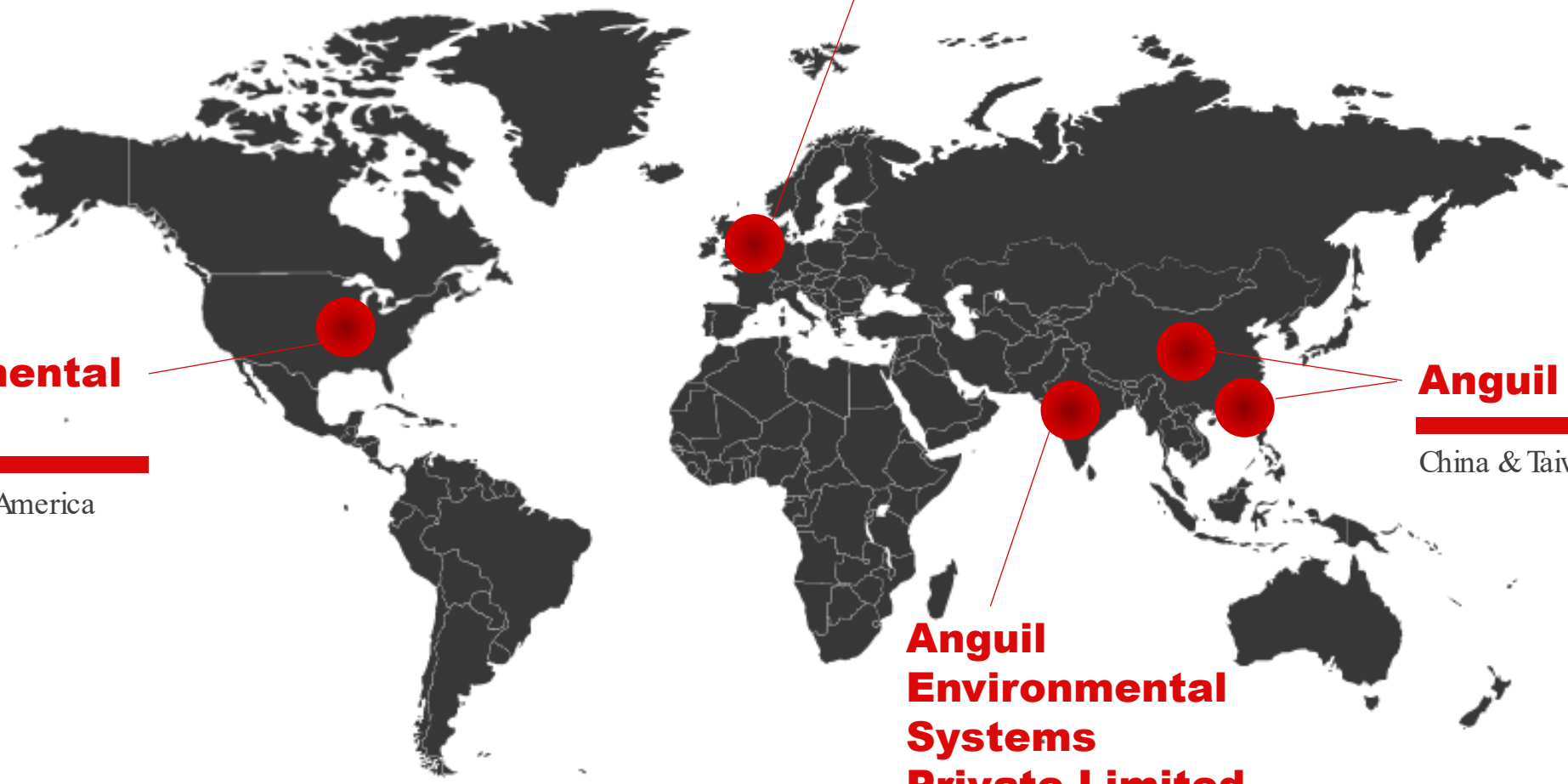

**Anguil has dozens of abatement installations on battery production, testing and recycling!**

# Capabilities

## SYSTEM ENGINEERING

Our engineering expertise, thorough design techniques, and wide breadth of pollution control technologies make Anguil the first choice for dependable solutions.



## POLLUTION CONTROL EQUIPMENT

Thermal and catalytic oxidizer technologies, turnkey wastewater treatment systems, and heat recovery solutions.

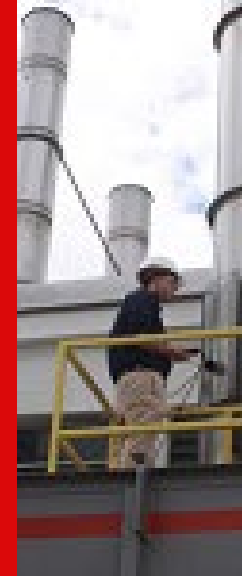

## AFTERMARKET SERVICES

Maintenance, service, repair, upgrades, and retrofits for Anguil systems as well as systems manufactured by others.

**ANGUIL**<sup>™</sup>

## INDUSTRY SPECIFIC SOLUTIONS

- Cell Coating & Finishing Solvent Abatement
- Material Mining & Active Material Processing
- Battery Recycling and more...
- Electrode Parts Washing
- Kiln & Furnace Emission Control

# Anguil's Critical Role in the Lithium-Ion Battery Value Chain

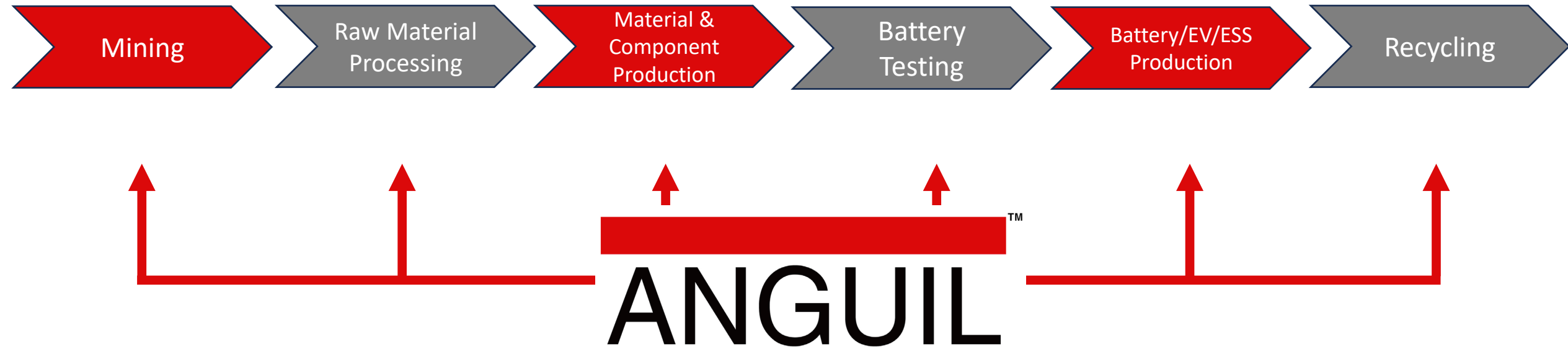

# What is Oxidation?

**TREATING**  
Methanol, ethanol, EMC, DMC, CO, C<sub>2</sub>H<sub>2</sub>, H<sub>2</sub>, HF and more...



## TIME

Relates to how long a compound needs to be at a certain temperature in order for it to be oxidized.



## TEMPERATURE

Based on the VOCs that need to be destroyed, there is a temperature at which the compounds can be oxidized.



## TURBULENCE

A fixed condition built into the equipment design that ensures a proper mixture of VOCs and oxygen for combustion.



Specific compounds and desired destruction rate efficiency determine temperature and residence time.

# Gas Phase Oxidation Treatment Systems

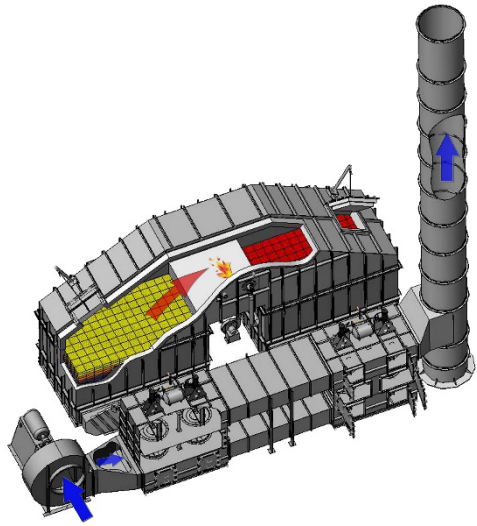

Regenerative  
Thermal Oxidizer  
(RTO)

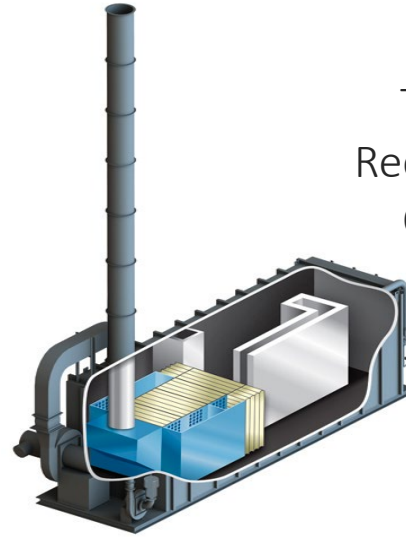

Thermal  
Recuperative  
Oxidizer

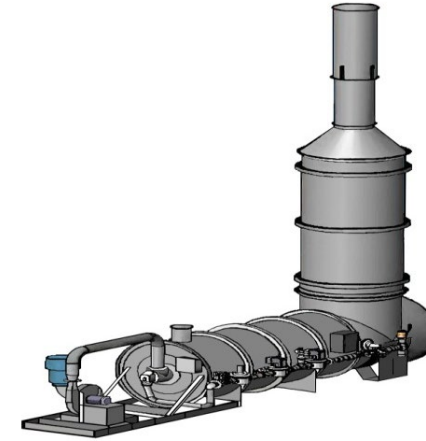

Direct-Fired  
Thermal Oxidizer  
(DFTO)



Catalytic  
Recuperative  
Oxidizer

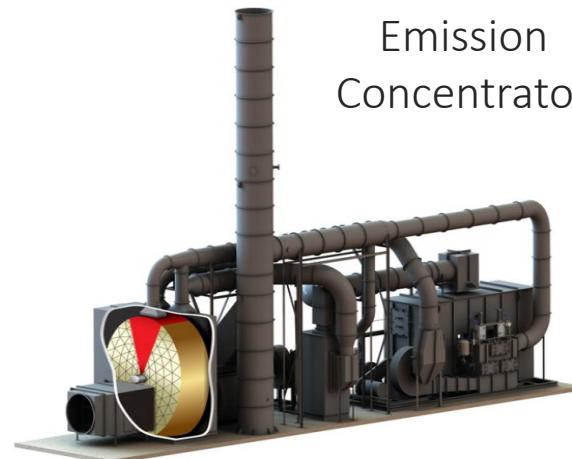

Emission  
Concentrator

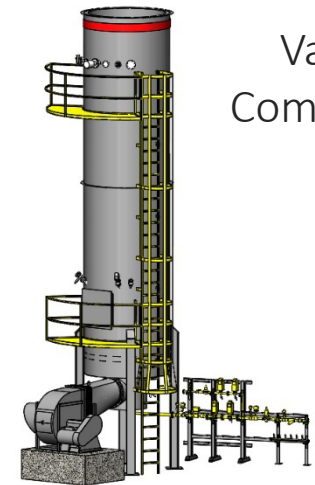

Vapor  
Combustor

**Acid gas removal systems can also be incorporated**

# Lower Carbon Footprint Systems

- Alternate heating sources (electric or hydrogen) replace natural gas burners
- Minimize the amount of CO<sub>2</sub> and NO<sub>x</sub> created during the oxidation process while maintaining destruction efficiencies
- Available in catalytic and thermal oxidizers
- CFD proven designs

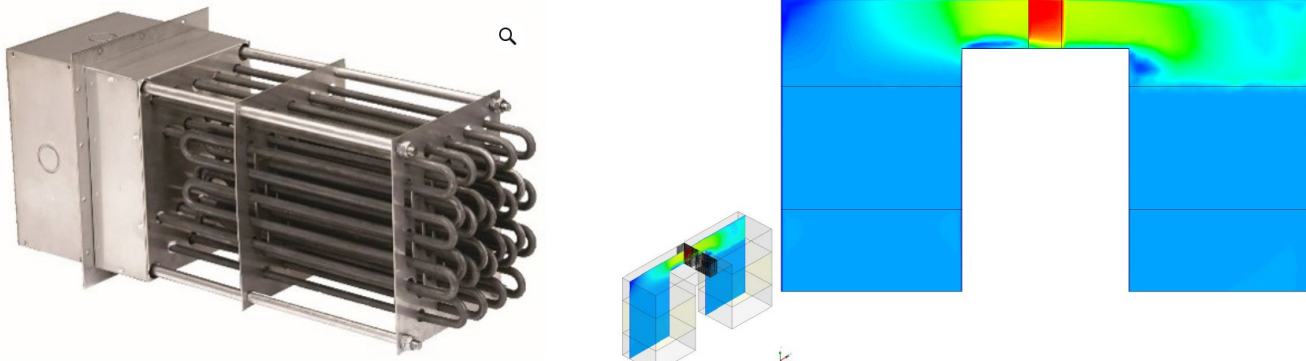



# Regenerative Thermal Oxidizer (RTO) Overview

AIR FLOW RANGE

2,500-70,000  
SCFM  
Single Unit

CONCENTRATION  
RANGE

0 – 25%  
LEL

THERMAL ENERGY  
RECOVERY

True 95%+

DESTRUCTION  
RATE EFFICIENCY (DRE)

99%+



INDUSTRY FOCUS

**RTOs are ideal for active anode material (AAM),  
cathode active material (CAM), coating, recycling,  
& battery testing!**

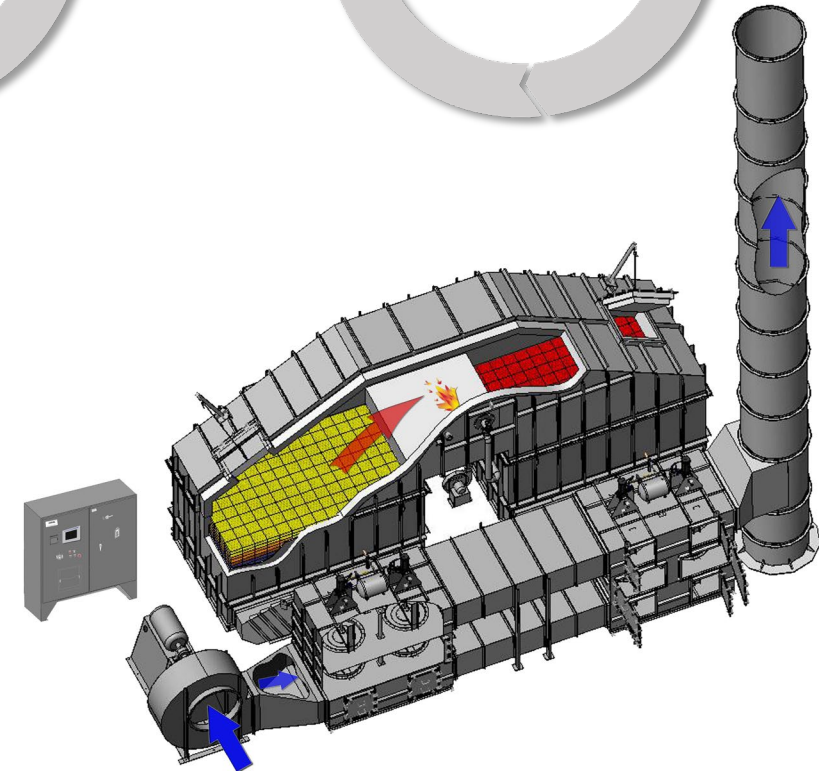



# Solutions in Action | **Regenerative Thermal Oxidizer (RTO)**

## **Battery Applications Using RTOs**

- Synthetic graphite anode battery powder thermal processing application
- Battery recycling facility
- Cell/pack coating applications
- Battery testing facility



# Direct Fired Thermal Oxidizer (DFTO) Overview

AIR FLOW RANGE

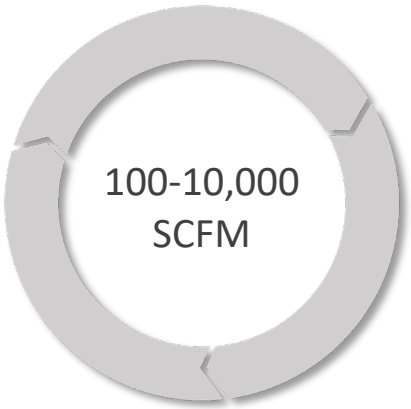

CONCENTRATION RANGE

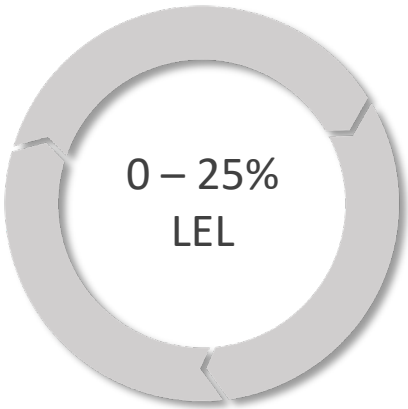

THERMAL ENERGY RECOVERY



DESTRUCTION & REMOVAL EFFICIENCY (DRE)

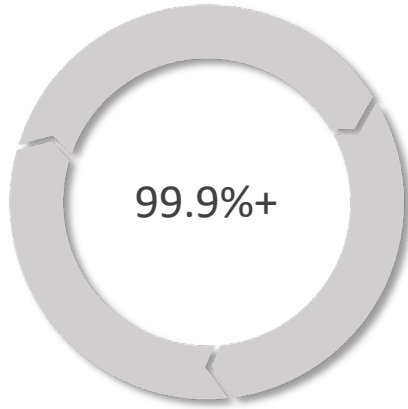

 APPLICATIONS



INERT GASES



LOW PROCESS VOLUME



VARYING PROCESS CONDITIONS



HIGH DESTRUCTION EFFICIENCY REQUIREMENTS

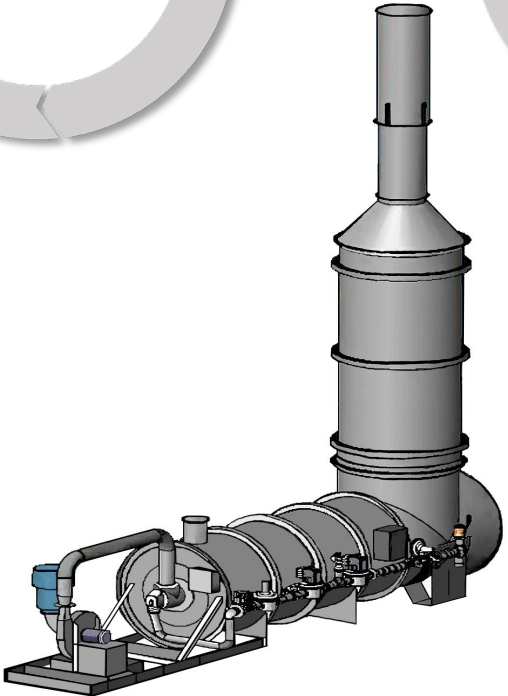

INDUSTRY FOCUS

**DFTOs are Ideal for Kiln and Calciner Exhausts as well as Graphite and LFP Processing and Coating Applications!**



## Solutions in Action | **Direct Fired Thermal Oxidizer (DFTO)**

### **Battery Applications using DFTOs**

- Natural graphite anode coating and thermal processing applications
- Silicone-carbon anode processing facility
- Hard rock lithium mining processing facility





# Solutions in Action | **Battery Components**

## **System**

Three (3) 34,000 SCFM (53,620 Nm<sup>3</sup>/h) Rotor Concentrator wheels  
coupled with

Three (3) 7,000 SCFM (11,040 Nm<sup>3</sup>/h) **Electric**  
Regenerative Catalytic Oxidizers (RCOs)

Battery module coating application.

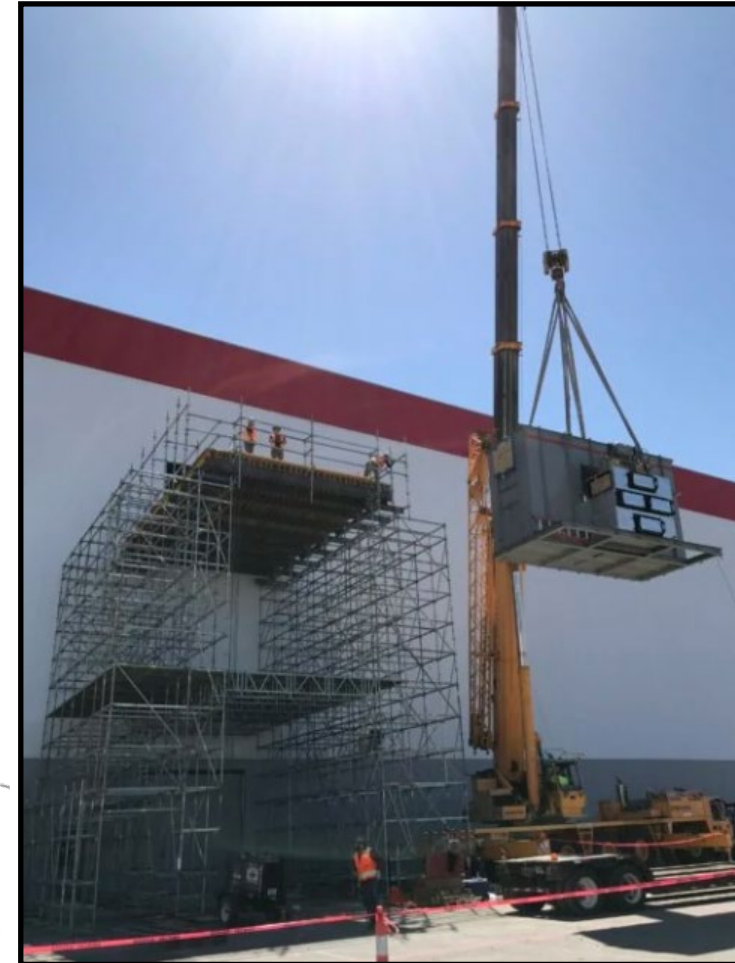
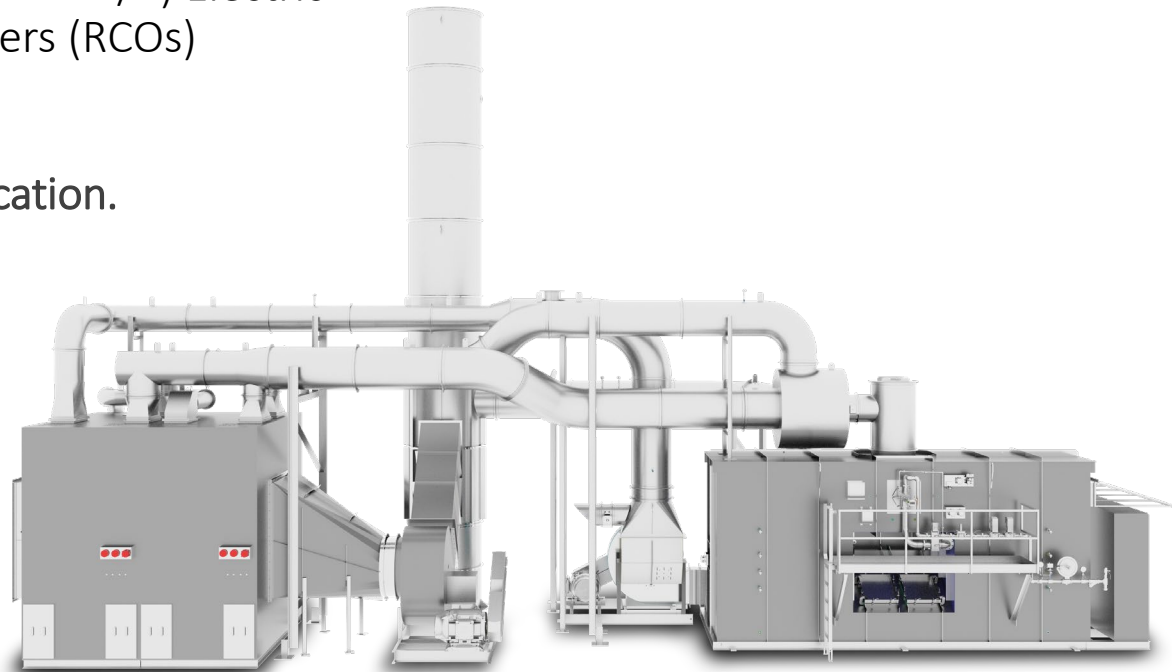



# Solutions in Action | **Battery Components**

## **System**

Thermal Recuperative Oxidizer 11,000 SCFM (17,655 Nm<sup>3</sup>/h)

Battery Module Coating Application.

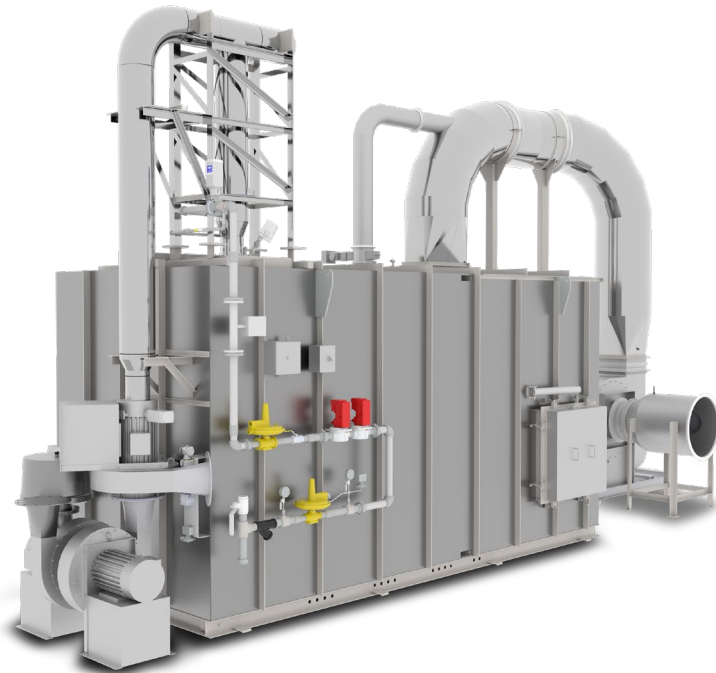

# Anguil Industrial Water

- North American System Integrator providing industrial process and wastewater treatment system.
- Leveraging over 40 engineers and technical personnel to design and deliver the most cost-effective systems that can meet your needs.

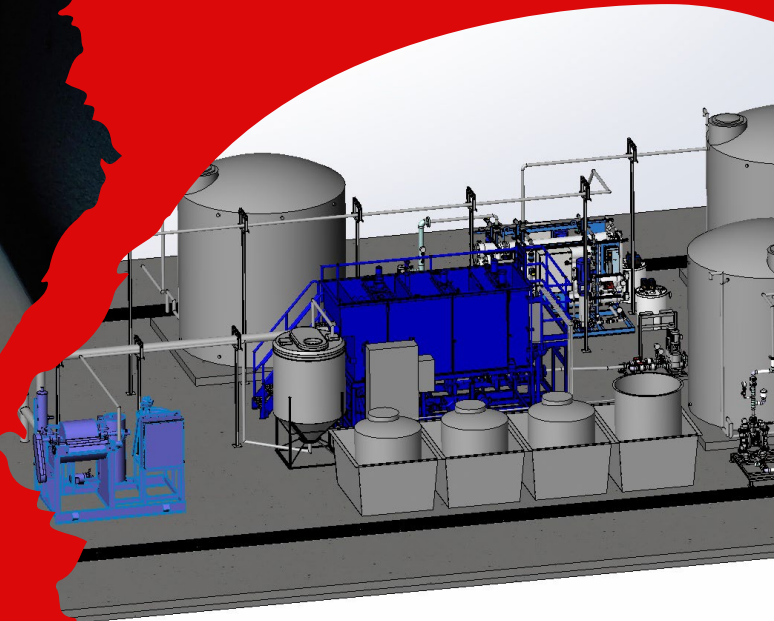
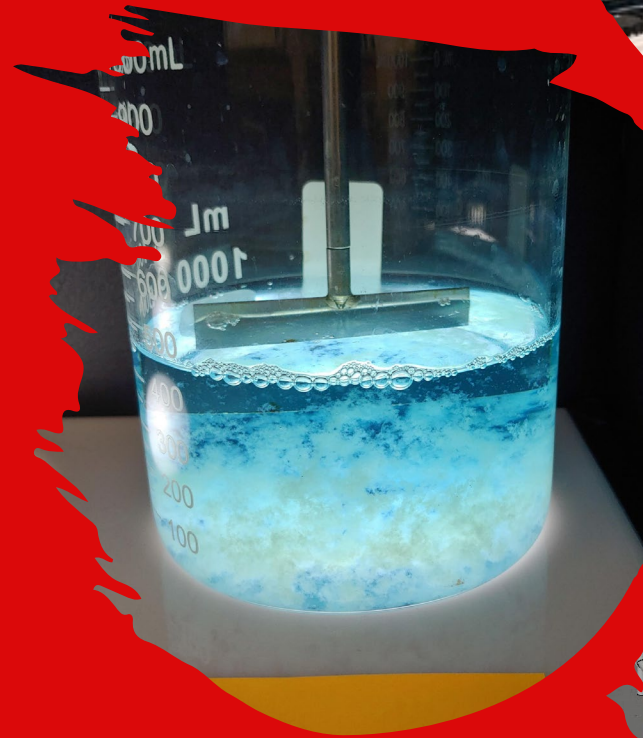

**From Wet Lab & Pilot Systems to Turn-Key Installations**

# Thank You!

---

## **MAILING ADDRESS**

8855 N 55<sup>th</sup> St Milwaukee, WI 53223

## **EMAIL ADDRESS**

[info@Anguil.com](mailto:info@Anguil.com)

## **PHONE**

(414) 365-6400

## **WEB SITE**

[www.Anguil.com](http://www.Anguil.com)

---

**ANGUIL**<sup>™</sup>



**We Don't Walk Away.**

